

# Product datasheet

Dock shelter  
Crawford DS6070E

**ASSA ABLOY**

ASSA ABLOY Entrance Systems

The global leader in  
door opening solutions



# Copyright and Disclaimer Notice

Although the contents of this publication have been compiled with the greatest possible care, ASSA ABLOY Entrance Systems cannot accept liability for any damage that might arise from errors or omissions in this publication. We also reserve the right to make appropriate technical modifications/replacements without prior notice.

No rights can be derived from the contents of this document.

Color guides: Color differences may occur due to different printing and publication methods.

ASSA ABLOY, Besam, Crawford, Megadoor and Albany, as words and logos, are examples of trademarks owned by ASSA ABLOY Entrance Systems or companies within the ASSA ABLOY Group.

Copyright © ASSA ABLOY Entrance Systems AB 2006-2014.

No part of this publication may be copied or published by means of scanning, printing, photocopying, microfilm or any other process whatsoever without prior permission in writing by ASSA ABLOY Entrance Systems.

All rights reserved.

# Technical facts

## Features

Sizes - nominal height	3775, 3925, 4375 mm
Sizes - nominal width	3250, 3550 mm
Sizes - nominal depth	1080 mm
Sizes - side bag extension	350 mm (standard for NW=3250) "S" 500 mm (standard for NW=3550) "L"
Sizes - top bag extension	800, 900 mm
Front plate	RAL 9010 or RAL 9005
Control unit	Switch control

## Performance

Roof:	Sheet plate, RAL 9005 black
Front plate:	Steel sheet galvanized
Fabric quality:	Top and side bag chloroprene coated polyamide fabric 410 g/m <sup>2</sup> , thickness 0,5 mm
Fan:	230V, 50 Hz, 1,8A 400V, 50 Hz, 1,8A Noise niveau: 75dBa in working position
Temperature:	-30° to + 70°

# Contents

Copyright and Disclaimer Notice .....	2
Technical facts .....	3
Contents .....	4
1. Description .....	5
1.1 Application .....	5
1.2 Mode of operation .....	5
1.3 Overview .....	5
1.4 Standard .....	5
1.5 Options .....	5
2. Specifications .....	6
2.1 Dimensions .....	6
2.2 Material .....	6
3. Construction .....	7
3.1 Construction views .....	7
4. Building and space requirements .....	8
4.1 Wall fixings .....	8
4.1.1 Concrete wall .....	8
4.1.2 Steel wall .....	8
4.2 Fixing points .....	9
5. Service .....	10
Index .....	11

# 1. Description

## 1.1 Application

The handling of cooled or frozen food put high demands on the temperature chain, the inflatable shelter is a key component of a preferred loading bay design. The unique feature of the Crawford DS6070E inflatable dock shelter economic is the long life time rubber coated fabric of the airbags, which facilitates very flexible sealing of the vehicle movements during loading and unloading. The simple design of the seal is outstanding, only consisting of a roof part with fixings and the sealing airbags. It has no wall construction around the side bags that can be damaged by the loading vehicles during dock-in manoeuvring, and when the Crawford DS6070E inflatable dock shelter economic is deflated the side bags and the top bag are well protected.

## 1.2 Mode of operation

The truck is not driven into the shelter as usual but only after docking the Crawford DS6070E inflatable dock shelter economic will be inflated and put tightly around the coachwork. Due to this principle a unique adaptation to the most different kind of trucks can be obtained. The inflatable cushions being connected with each other are blown up and kept steadily under pressure during usage by a powerful but quiet blower. After loading is completed within seconds the side cushions are pulled aside automatically by tensioning ropes or counterweights and the top cushion is pulled up by a counterweight running on a shaft.

## 1.3 Overview

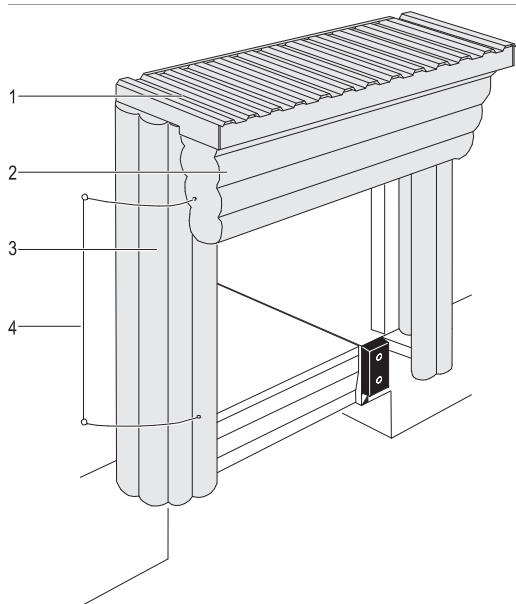

- 1) Trapezoidal plate
- 2) Top bag
- 3) Side bag
- 4) Tensioning rope

## 1.4 Standard

Nominal height	3775, 3925, 4375 mm	
Nominal width	3250, 3550 mm	
Nominal depth	1080 mm	
Top bag extension	800 mm	
Side bag extension	350 mm (standard for NW=3250) "S" 500 mm (standard for NW=3550) "L"	
Operating	Switch control	
Standard colour	Front plate	RAL 9010

## 1.5 Options

Top bag extension	1100 mm	
Colour	Front plate	RAL 9005
	Side brackets	
Front plate	Digit on front plate	
Side bag retraction	Counterweight with channel	
Wall fixings	Concrete, steel, insulated panel, light concrete, Load House	

## 2. Specifications

### 2.1 Dimensions



Abb.	Dimension	Value (mm)
NB	Nominal width	3250, 3550, 4375
NH	Nominal height	3775, 3925
NT	Nominal depth	1080
HO	Top bag travel	800, 1100
HS	Side bag travel	350 (NW=3250) "S" 350 (NW=3550) "L"

### 2.2 Material

The cushions are made up of a durable material with fabric inlay. The material is inflammable, light-proof, weather and wear resistant.

## 3. Construction

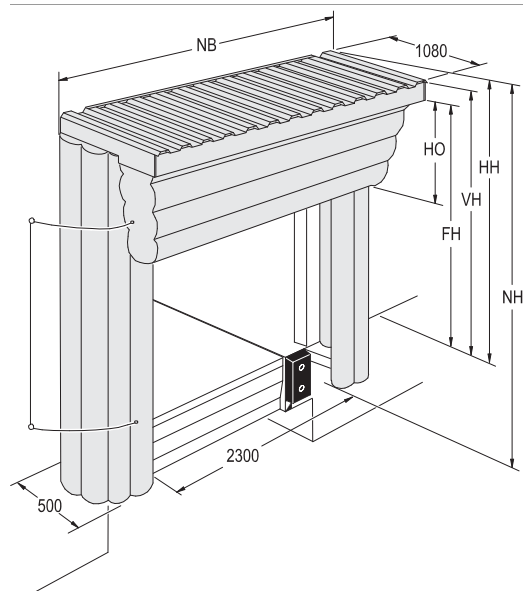
The Crawford DS6070E inflatable dock shelter economic can be fitted directly to the wall or on a Load House and is only available as a single module. The Crawford DS6070E inflatable dock shelter economic consists of two side walls with bags, front protections and installation material. Roof with top bag, front plate, machinery, fan and installation brackets. The Crawford DS6070E inflatable dock shelter economic is operated from a control panel and the supply contains the complete dock shelter including necessary fixings.

### 3.1 Construction views

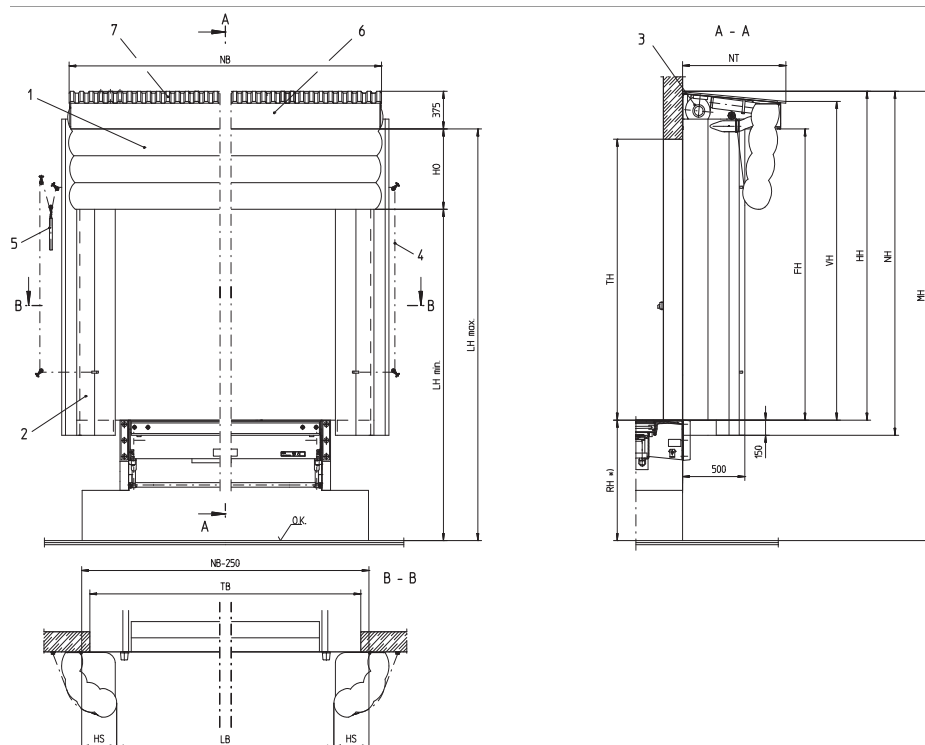

- 1 Top bag
- 2 Side bag
- 3 Blower
- 4 Tensioning rope
- 5 Counter weight
- 6 Front plate
- 7 Trapezoidal plate
- OK Yard level
- TB Door width
- NH Nominal height
- RH Dock height
- LB Clear width
- LH Clear height above yard level
- HH Total height bag above dock height
- VH Total height front above dock height
- NB Nominal width
- FH max. free height above dock level
- HO Travel top bag
- MH Installation height

## 4. Building and space requirements

### 4.1 Wall fixings

#### 4.1.1 Concrete wall

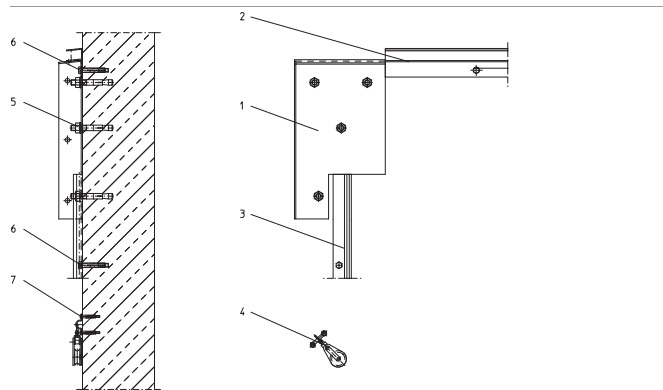

#### 4.1.2 Steel wall

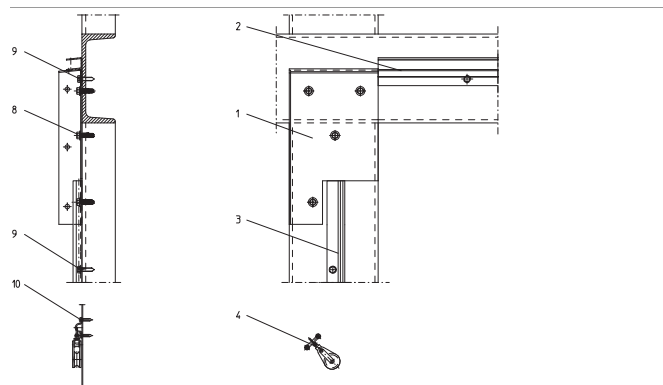

1	Console
2	F-profile top
3	C-profile side
4	Block pulley for tension rope
5	Heavy duty bolt $\varnothing$ 12
6	Dowel with slotted round head wood screw 8x60
7	Dowel with slotted round head wood screw 4x40
8	Self drilling screw with washer 9,5x32
9	Self tapping screw with washer 8x32
10	Self tapping screw 5.5x25

Note!  
 The wall surface at the installation point, NH + 150 mm und NB + 100 mm, should be smooth and flat!



## 4.2 Fixing points

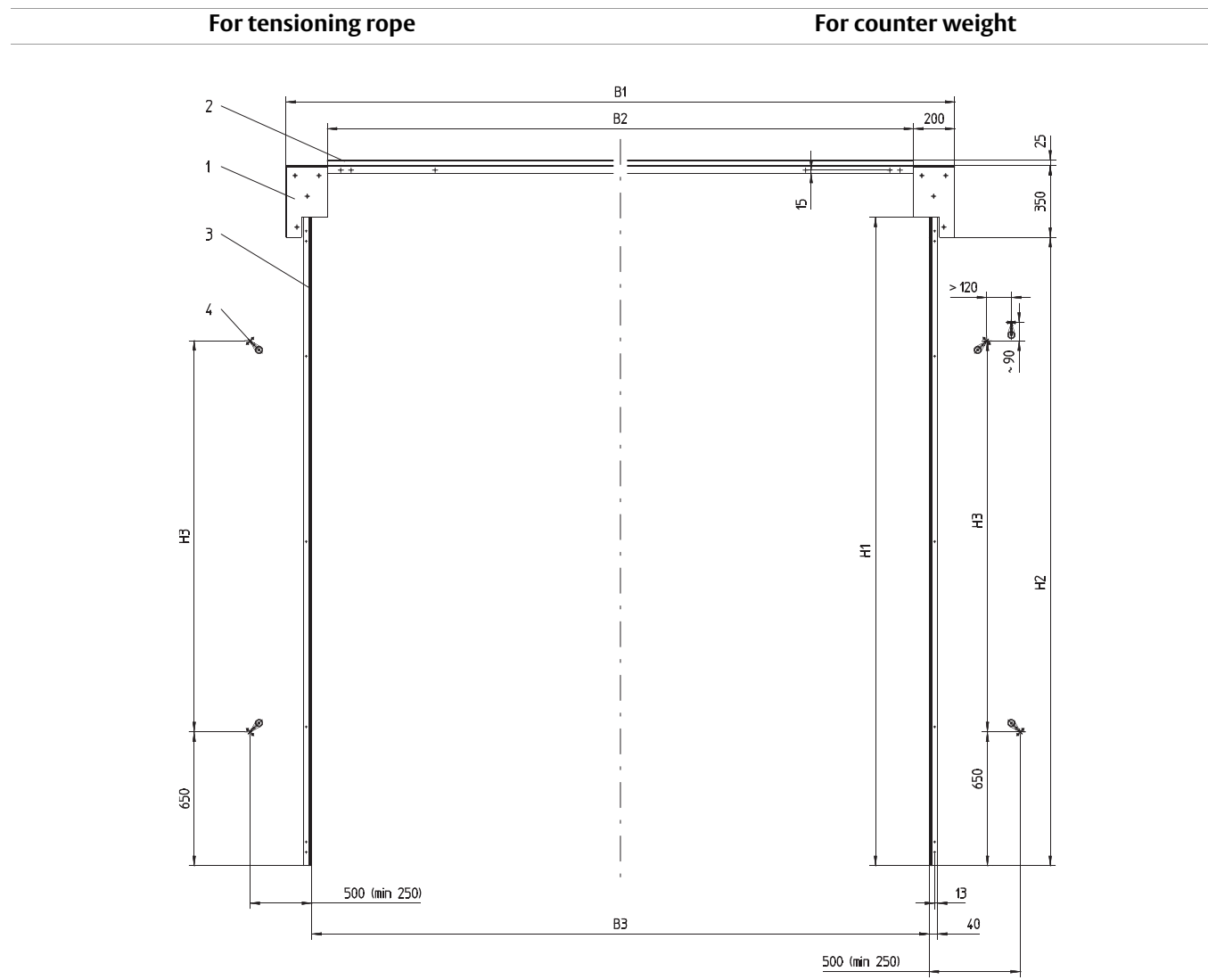

- X1 Console
- X2 F-profile top
- X3 C-profile side
- X4 Block pulley for tensioning rope
- NB Nominal width
- NH Nominal height

NH	H1	H2	H3
3775	3500	3402	2250
3925	3650	3552	2400
4375	4100	4152	3000
NB	B1	B2	B3
3250	3250	2850	3000
3550	3550	3150	3300

# 5. Service

## Preventive Maintenance Program and Modernization Services

As your entrances are part of your business flow, there's every reason to keep them working well. ASSA ABLOY Entrance Systems offers you a maintenance and modernization expertise to rely on. Our Maintenance Programs and Modernization Services are backed by a extensive expertise for all types of industrial door and docking systems, independent of brand. At your disposal is a team of dedicated expert technicians, proven through decades of maintenance, service and satisfied customers.

### Preventive Maintenance Programs

Minimizing lost time, lost energy and unexpected hassle is our team's constant objective. Our service organization can support you 24/7 in maintaining all industrial door and docking systems, independent of brand. If you want to be one step ahead of break-downs, explore our portfolio of Pro-Active Care plans. Naturally, we also offer entrance upgrades to suit your specific wishes and business needs.

### Pro-Active Care - Maintenance plans to fit your business

Regular maintenance can extend the lifetime of your equipment and help prevent unexpected problems. Our technician arrives on-site equipped with the knowledge and tools to service all automatic entrances, independent of brand.

- **Pro-Active Bronze**

The base on which all Pro-Active Plans are built provides the security of knowing that your equipment is regularly inspected and certified for safety, as well as performing optimally. It includes a number of planned on-site visits depending on your needs. Any unplanned service calls required during the term of the contract (including labor, travel and parts) are billed at special Pro-Active Care prices.

- **Pro-Active Silver**

This plan provides all the benefits of Pro-Active Bronze with the added advantage of labor and travel being included for service calls during regular business hours. The only additional charge would be for any parts that may be needed throughout the term of the contract.

- **Pro-Active Gold**

This plan provides the ultimate protection for your automatic entrance investment. It includes all the benefits of Pro-Active Silver, plus replacement of any parts required during an unplanned repair or planned maintenance visit. Pro-Active Gold is an excellent way to budget your automatic door expenses annually.

- **Pro-Active Tailor-Flex**

Our most flexible maintenance and service offering. The Pro-Active Care plan is designed by you, our customer. The plan allows you to balance your maintenance expenses against your real-world budget and presents the option to add or delete a number of maintenance elements to suit your budget goals, while meeting your overall performance and safety needs.

### Modernization

Your entrances are a long-term investment, from which you always want the best. Products develop over time, so do regulations and your business. Let us help you increase energy savings and meet today's standards. We provide advice and modernization kits for outdated installations, ensuring your investment meet requirements and performs optimally for many more years to come.

Re-Active Service		Pro-Active Care				
Corrective	SafetyCheck	Pro-Active Bronze	Pro-Active Silver	Pro-Active Gold	Pro-Active Tailor Flex	
		○	○	○	●	Other customized requests such as Response Time, Performance InfoPack and Advanced User Training
		○	○	●	○	Replacement of worn parts according to preventive Consumable Exchange Program
		○	○	●	○	Replacement of spare parts on breakdowns
		○	●	●	○	Travel and labor for additional call-out visits
		●	●	●	●	Preventive maintenance visits 1-4 times per year
		●	●	●	●	Travel and labor for preventive maintenance visits
		●	●	●	●	Response time and priority on call-outs <24h
		●	●	●	●	Preventive planned maintenance that meets the most demanding standards in the market
	●	●	●	●	●	Safety and quality checks according to applicable regulations and norms. Documentation of test results provided
●	●	●	●	●	●	Documentation of equipment status, assessment and service provided, all generated on site
●	●	●	●	●	●	Highly trained professional technicians with extensive knowledge, state-of-the-art tools and the right spare parts*
●	●	●	●	●	●	Dedicated Professional Customer Care Hotline

● = Included as standard  
 ○ = Available at special prices  
 \* Well-stocked service vehicles with genuine and new spare parts

# Index

A	
Application .....	5
B	
Building and space requirements .....	8
C	
Concrete wall .....	8
Construction .....	7
Construction views .....	7
Copyright and Disclaimer Notice .....	2
D	
Description .....	5
Dimensions .....	6
F	
Features .....	3
Fixing points .....	9
M	
Material .....	6
Mode of operation .....	5
O	
Options .....	5
Overview .....	5
P	
Performance .....	3
S	
Service .....	10
Specifications .....	6
Standard .....	5
Steel wall .....	8
T	
Technical facts .....	3
W	
Wall fixings .....	8

ASSA ABLOY Entrance Systems is a leading supplier of entrance automation solutions for efficient flow of goods and people. With our globally recognized product brands Besam, Crawford, Megadoor and Albany, we offer products and services dedicated to satisfying end-user needs for safe, secure, convenient and sustainable operations.  
ASSA ABLOY Entrance Systems is a division within ASSA ABLOY.

**ASSA ABLOY**

[assaabloyentrance.com](http://assaabloyentrance.com)

Q2.0 - 2014



ASSA ABLOY Entrance Systems

Tel: +46 (0)10 4747 000  
[sales.aaes@assaabloy.com](mailto:sales.aaes@assaabloy.com)  
[assasabloyentrance.com](http://assasabloyentrance.com)