

# Docking drawbridge

## Crawford DB6050KBS

**ASSA ABLOY**

ASSA ABLOY Entrance Systems

The global leader in door opening solutions



### Compact movable drawbridge leveller

The Crawford DB6050KBS drawbridge leveller can be moved sideways in a guide rail principally designed for external applications. It is the flexible solution for the lower working range up to about 135 mm level equalization. The outstanding feature is the quick and easy handling.

The high-tensile light metal allows weights up to 40 kN. The Crawford DB6050KBS drawbridge leveller complies with the European EN 1398 standard.

Feature and benefits:

- Non slip surface for safe transshipment of goods
- Easy to keep clean
- Robust and maintenance free
- Easy Handling and flexible positioning

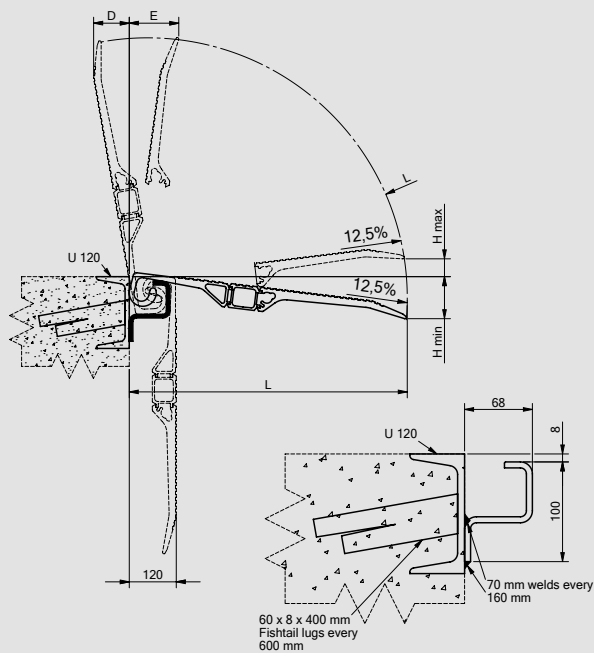

Type	Order Number	Length (L)	Width (B)	Dim. (A)	Height Difference (H)		Load Cap (kgs/ea)	Weight (kgs/ea)
					min.	max.		
KBS 00	302.21.000	410	1250	80	- 70	+ 30	4000	19
KBS 12	302.21.012	535	1250	100	- 90	+ 45	4000	24
KBS 13	302.21.013	785	1250	150	- 120	+ 75	4000	31
KBS 02	302.21.002	910	1250	170	- 135	+ 90	4000	36
KBS 04	302.21.004	410	1500	80	- 70	+ 30	4000	23
KBS 14	302.21.014	535	1500	100	- 90	+ 45	4000	28
KBS 15	302.21.015	785	1500	150	- 120	+ 75	4000	38
KBS 06	302.21.006	910	1500	170	- 135	+ 90	4000	44
								(kg/m)
	319.23.006	Guide rail, galvanized, 3000 mm long						8
	319.23.016	Guide rail, galvanized, 2500 mm long						8
	319.23.017	Guide rail, galvanized, 2000 mm long						8